

## CA1782-XXX-XX-BT DWDM High Power DFB Butterfly Laser

### Overview

The CA1782-XXX-XX-BT DWDM High Power DFB Butterfly Laser component is characterized for use as a CW optical source in CATV and DWDM networks. The CA1782-XXX-XX-BT is dc-coupled with a built-in TEC, thermistor, and monitor photodiode. The device is mounted in a 14-pin, OC-48 pinout compatible butterfly package with the optical isolator mounted on the TEC. The CA1782-XXX-XX-BT incorporates a high efficiency coupling scheme to deliver 40 mW, 50 mW, 63 mW and 100 mW of CW optical power.

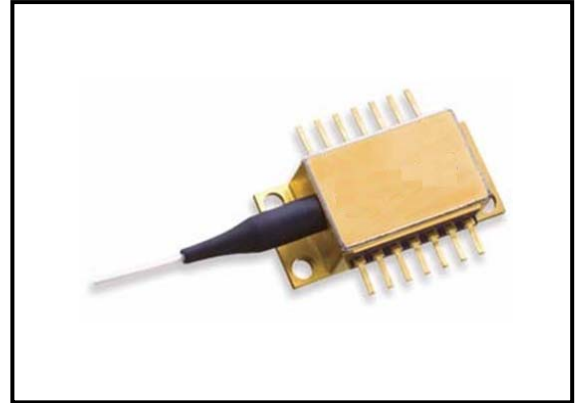

### Applications

- DWDM
- CATV
- Free Space Optics

### Features

- 40, 50, 63 & 100 mW Optical Output Power
- OC-48 Pinout Compatible
- Telcordia Technologies™ GR-468 Compliant
- PM Fiber
- -20°C to +65°C Operating Temperature Range
- Monitor Photodiode RoHS

## Specification

Parameter	Min	Typ	Max	Units
Operating Case Temperature	-20	25	+65	°C
Wavelength	See Page 4			nm
Optical Output Power	40 50 63 100	- - - -	- - - -	mW
Threshold Current	-	-	40	mA
Operating Current	-	-	650	mA
RIN	-	-	-163	dB/Hz
RIN Through 65 km Fiber				
	Standard	-	-155	dB/Hz
	Enhanced	-	-157	dB/Hz
SMSR	30	-	-	dB
Polarization Extinction Ratio (PMF pigtail)	17	-	-	dB
Optical Isolation	32	-	-	dB
Optical Return Loss	40	-	-	dB

## Absolute Maximum Ratings

Stresses in excess of the absolute maximum ratings can cause permanent damage to the device. These are absolute stress ratings only. Functional operation of the device is not implied at these or any other conditions in excess of those given in the operational sections of the data sheet. Exposure to absolute maximum ratings for extended periods can adversely affect device reliability.

Parameter	Symbol	Condition	Min	Max	Units
Operating Case Temperature	T <sub>OP</sub>	continuous	-20	+65	°C
Storage Temperature	T <sub>STG</sub>	continuous	-40	+85	°C
Laser Forward dc Current	-	continuous	-	750	mA
Photodiode Reverse Voltage	V <sub>R,MPD</sub>	continuous	-	10	V
Laser Reverse Voltage	-	continuous	-	2	V
TEC current	I <sub>TEC</sub>	continuous	-	1.7	A
ESD	-	HBM: R = 1500 Ω, C = 100 pF	-500	500	V

## Electrical/Optical Characteristics

Parameter	Symbol	Condition	Min	Typ	Max	Unit
Operating Case Temperature <sup>1</sup>	T <sub>OP</sub>	-	-20	25	65	°C
Optical Output Power	P <sub>O</sub>	40 mW version, T = T <sub>set</sub> , I <sub>F</sub> = I <sub>OP</sub> 50 mW version, T = T <sub>set</sub> , I <sub>F</sub> = I <sub>OP</sub> 63 mW version, T = T <sub>set</sub> , I <sub>F</sub> = I <sub>OP</sub> 100 mW version, T = T <sub>set</sub> , I <sub>F</sub> = I <sub>OP</sub>	40 50 63 100	- - - -	- - - -	mW
Threshold Current	I <sub>TH</sub>	BOL	-	-	40	mA
Operating Current	I <sub>OP</sub>	BOL	-	-	500	mA
Operating Laser Temperature	-		23	-	33	°C
Laser Bias Forward Voltage	V <sub>OP</sub>	BOL, I <sub>F</sub> = I <sub>OP</sub>	-	-	2.5	V
Wavelength	λ <sub>OP</sub>	T = T <sub>set</sub> , I <sub>F</sub> = I <sub>OP</sub>	See Page 4			nm
Spectral Linewidth <sup>(1)</sup>	Δλ	T = T <sub>set</sub> , I <sub>F</sub> = I <sub>OP</sub> , FWHM	-	-	1.0	MHz
Optical Isolation	ISO	-	32	-	-	dB
Optical Return Loss	ORL	-	40	-	-	dB
Sidemode Suppression Ratio	SMSR	-	30	-	-	dB
Polarization Extinction Ratio	PER	I <sub>F</sub> = I <sub>OP</sub>	17	-	-	dB
Wavelength Drift Over T <sub>C</sub> Range	Δλ <sub>TOP</sub>	T = T <sub>OP</sub>	-	-	40	pm
Relative Intensity Noise	RIN	-	-	-	-163	dB/Hz
Monitor PD Current	I <sub>MPD</sub>	I <sub>F</sub> = I <sub>OP</sub> , V <sub>MPD</sub> = -5V	100	-	2500	μA
Monitor PD Dark Current	I <sub>D</sub>	I <sub>OP</sub> = 0 mA, V <sub>MPD</sub> = -5V	-	-	0.2	μA
Thermistor Resistance	R <sub>TH</sub>	T <sub>OP</sub> = 25 °C	9.5	10.0	10.5	KΩ
Thermistor Temp. Coefficients	TC <sub>TH</sub>	T <sub>OP</sub> = 25 °C	-	-4.4	-	%/°C
TEC Current	I <sub>TEC</sub>	-20°C < T <sub>C</sub> < +65°C	-1.0	-	+1.5	A
TEC Voltage	V <sub>TEC</sub>	-20°C < T <sub>C</sub> < +65°C	-2.0	-	+3.0	V

1. Linewidth (Δν) is calculated using this formula:  $\Delta\nu = \Delta RIN(f) \{16\pi(D\lambda^2L/c)2f^2\} - 1$

Where: D = fiber dispersion; L = fiber length (65km); C = velocity of light in free space (3.00E+8); λ = opt center wavelength

$\Delta RIN(f)$  = RIN through fiber (RIN<sub>65km</sub> – RIN<sub>0km</sub>); f = the measurement frequency (860MHz)

## Outline Drawing

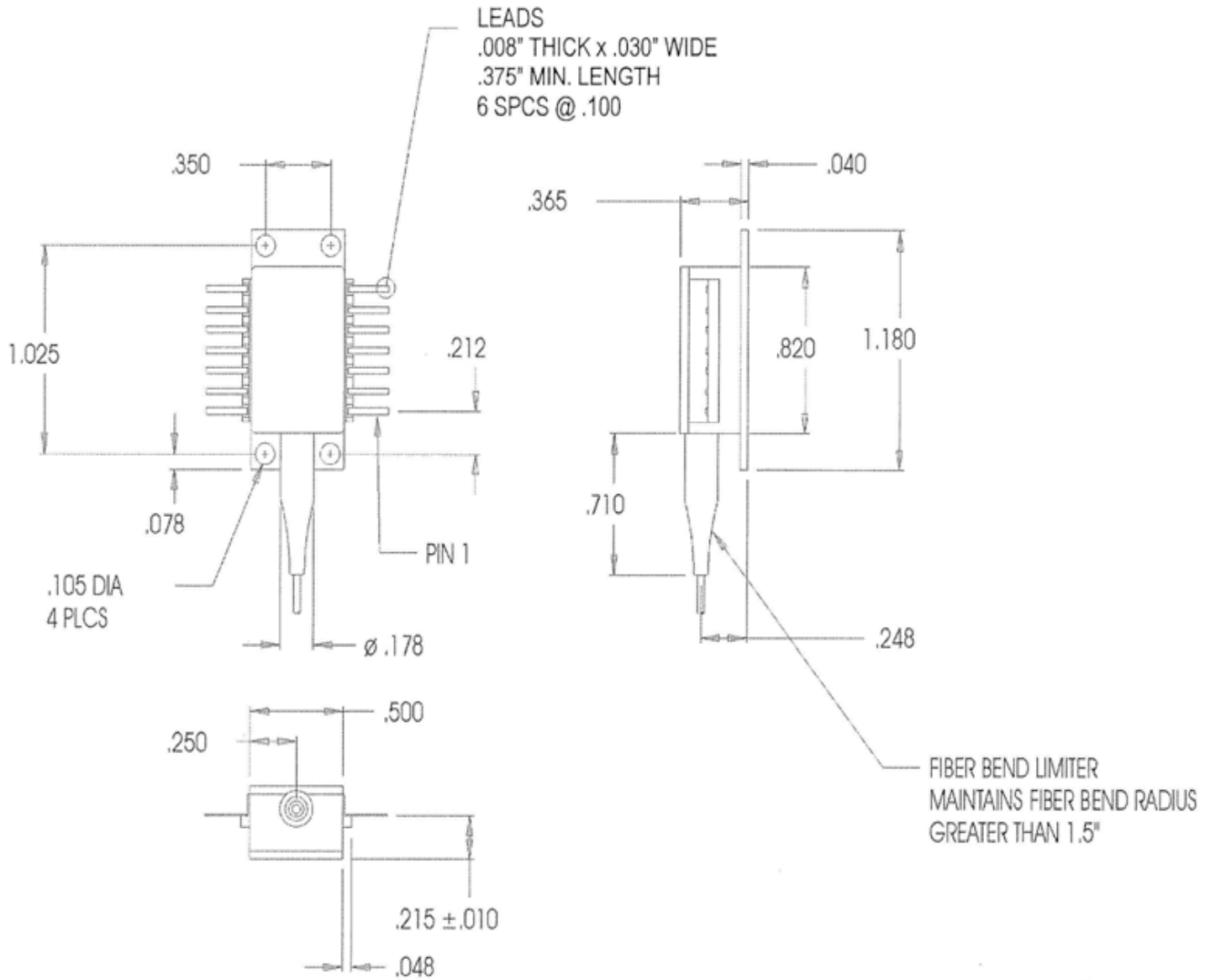

## Pin Assignments

Pin	Description
1	Thermistor
2	Thermistor
3	Dc Laser Bias (-)
4	MPD Anode (-)
5	MPD Cathode (+)
6	Thermal Electric Cooler (+)
7	Thermal Electric Cooler (-)
8	Case Ground
9	Case Ground
10	NC
11	Laser Common (+), Case Ground
12	Laser Modulation (-)
13	Laser Common (+)
14	NC

## ITU Grid Channel Numbering

Please contact CA OPTRONICS GROUP, INC. Sales for ITU Wavelength Channel availability.

## Package Schematic

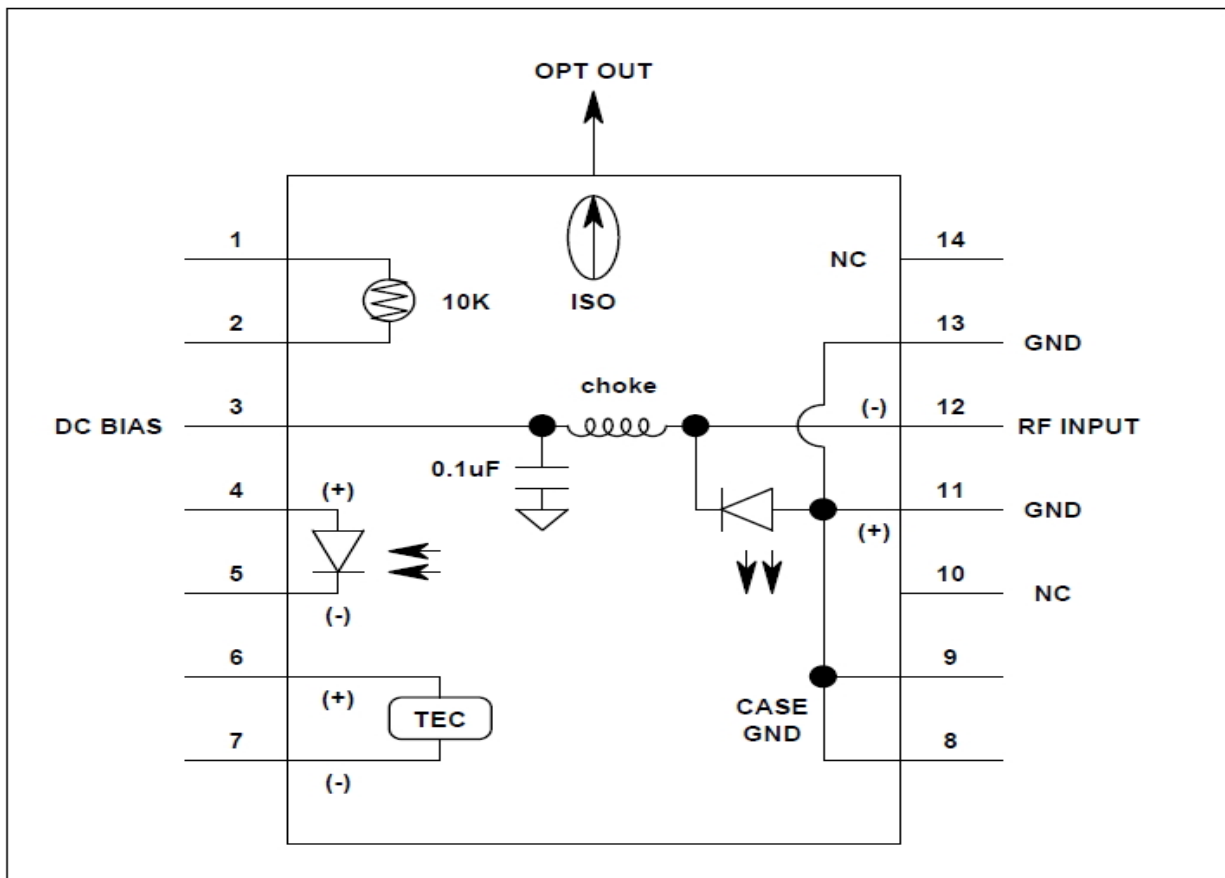

## Ordering Code Definitions

### CA1782 - xxx - yy - EM

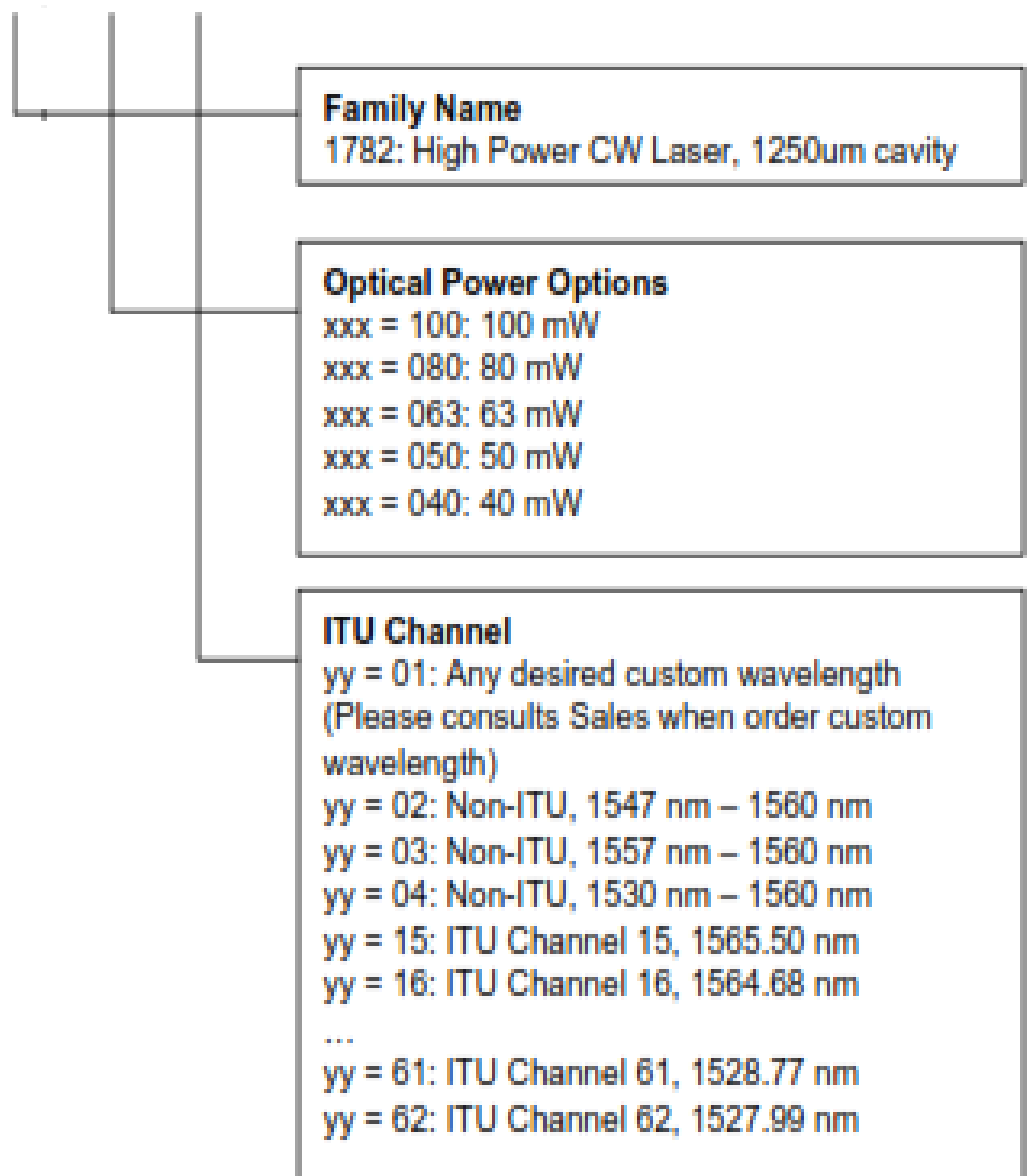

## Safety Information

- The laser light emitted from this laser diode is invisible and potentially harmful to the human eye. Avoid eye and skin exposure to the beam, both direct and reflected.
  - Products are subject to the risks normally associated with sensitive electronic devices including static discharge, transients, and overload. Please ensure ESD protection prior to handling the products.
  - These CA OPTRONICS products are not intended for use in systems where product malfunction can reasonably be expected to result in personal injury.
- Package Dimensions (Unit: mm)

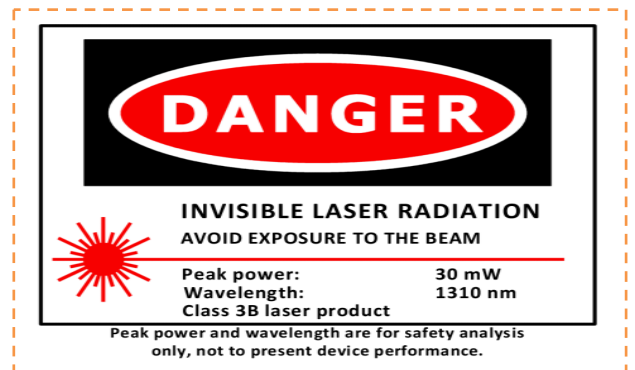

## Liability Note:

This document is sole property of CA OPTRONICS GROUP, Inc. No part of this document may be copied without written acceptance of CA OPTRONICS GROUP, Inc. All statements related to the products herein are believed to be reliable and accurate. However, the accuracy is not guaranteed and no responsibility is assumed for any inaccuracies or omissions. CA OPTRONICS GROUP, Inc. reserves the right to make changes in the specifications at any time without prior notice.